

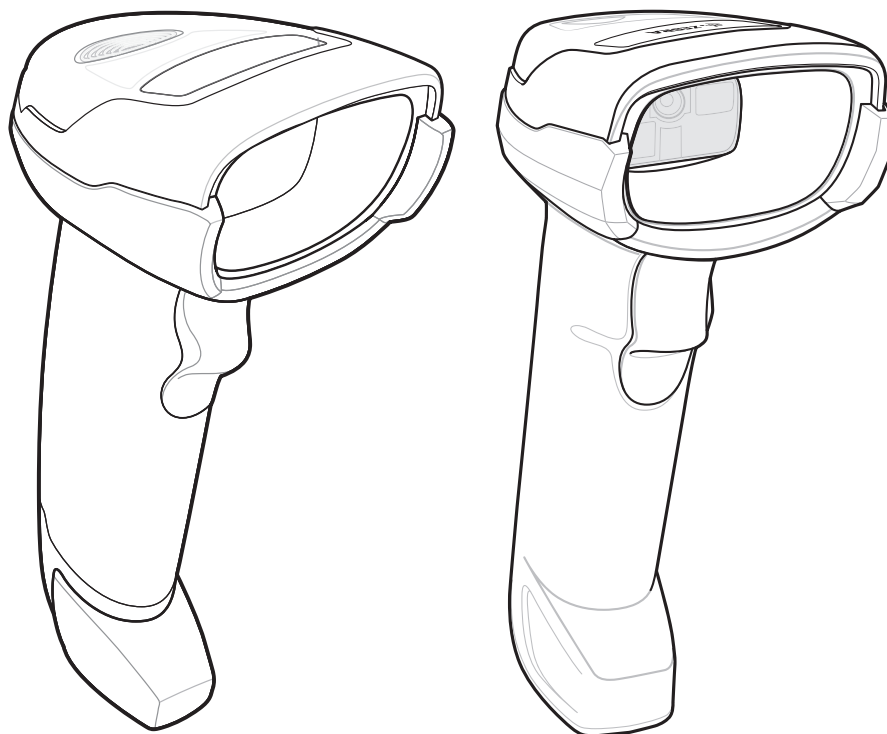

DS2208-HC & DS2778-HC



Digital Scanner

Product Reference Guide Supplement



**DS2200-HC & DS2278-HC DIGITAL SCANNER
PRODUCT REFERENCE GUIDE
SUPPLEMENT**

MN-003641-01

Revision A

August 2019

No part of this publication may be reproduced or used in any form, or by any electrical or mechanical means, without permission in writing from Zebra. This includes electronic or mechanical means, such as photocopying, recording, or information storage and retrieval systems. The material in this manual is subject to change without notice.

The software is provided strictly on an “as is” basis. All software, including firmware, furnished to the user is on a licensed basis. Zebra grants to the user a non-transferable and non-exclusive license to use each software or firmware program delivered hereunder (licensed program). Except as noted below, such license may not be assigned, sublicensed, or otherwise transferred by the user without prior written consent of Zebra. No right to copy a licensed program in whole or in part is granted, except as permitted under copyright law. The user shall not modify, merge, or incorporate any form or portion of a licensed program with other program material, create a derivative work from a licensed program, or use a licensed program in a network without written permission from Zebra. The user agrees to maintain Zebra’s copyright notice on the licensed programs delivered hereunder, and to include the same on any authorized copies it makes, in whole or in part. The user agrees not to decompile, disassemble, decode, or reverse engineer any licensed program delivered to the user or any portion thereof.

Zebra reserves the right to make changes to any product to improve reliability, function, or design.

Zebra does not assume any product liability arising out of, or in connection with, the application or use of any product, circuit, or application described herein. No license is granted, either expressly or by implication, estoppel, or otherwise under any patent right or patent, covering or relating to any combination, system, apparatus, machine, material, method, or process in which Zebra products might be used. An implied license exists only for equipment, circuits, and subsystems contained in Zebra products.

Warranty

For the complete hardware product warranty statement, go to: <http://www.zebra.com/warranty>.

Revision History

Changes to the original guide are listed below:

Change	Date	Description
-01 Rev. A	8/2019	Initial Release

TABLE OF CONTENTS

Warranty	ii
Revision History	ii

About This Guide

Introduction	v
Configurations	v
Related Product Line Configurations	vi
Cables	vi
Chapter Descriptions	vi
Notational Conventions	vi
Related Documents	vii
Service Information	vii
Provide Documentation Feedback	viii

Chapter 1: Getting Started

Introduction	1-1
Interfaces	1-2
Unpacking	1-2
Setting Up the DS2208-HC	1-3
Installing the Interface Cable	1-3
Removing the Interface Cable	1-4
Connecting Power (if required)	1-4
Configuring the Digital Scanner	1-4
Accessories	1-4
Setting up the DS2278-HC	1-5
Cradle Features	1-5
Using a DC Power Supply	1-6
Charging the DS2278-HC Battery	1-6
Charging Using the Cradle	1-6
Presentation Cradle	1-7
Connecting the Cradle	1-7
Changing the Host Interface	1-7
Charging Using the Micro USB Cable	1-8
Shutting Off the Digital Scanner Battery	1-9

Inserting the Battery	1-9
Removing the Battery	1-10
Inserting the DS2778-HC in the Cradle	1-11
Sending Data to the Host Computer	1-11
Pairing	1-11
Lost Connection to Host	1-12
Accessories	1-12

Chapter 2: Maintenance & Technical Specifications

Introduction	2-1
Maintenance	2-1
Known Harmful Ingredients	2-1
Approved Cleaners	2-2
Cleaning the Digital Scanner	2-2
Technical Specifications	2-3

Chapter 3: User Preferences & Miscellaneous Options

Introduction	3-1
Setting Parameters	3-1
Scanning Sequence Examples	3-2
Errors While Scanning	3-2
User Preferences/Miscellaneous Options Parameter Defaults	3-2
User Preferences	3-3
Default Parameters	3-3
Do Not Disturb Mode (Direct Decode Indicator)	3-4

Chapter 4: Symbologies

Introduction	4-1
Setting Parameters	4-1
Scanning Sequence Examples	4-2
Errors While Scanning	4-2
Symbology Parameter Defaults	4-2
Enable/Disable All Code Types	4-3
ISBT Concatenation	4-4
Code 128 Security Level	4-5
Code 128 Security Level (continued)	4-6
Composite	4-7
Composite CC-C	4-7
Composite CC-A/B	4-7

Index

ABOUT THIS GUIDE

Introduction



IMPORTANT

Refer to the DS2208 Digital Scanner Product Reference Guide, p/n MN-002874-xx and the DS2278 Digital Scanner Product Reference Guide, p/n MN-002974-xx, for all interface setups, LED and beeper indications, standard programming barcodes, and miscellaneous features.

The *DS2208-HC and DS2278-HC Product Reference Guide Supplement* provides general instructions for setting up, operating, and maintaining the DS2200 for Healthcare Series of digital scanners.

Configurations

This guide includes the DS2208-HC and DS2278-HC series digital scanner configurations listed in [Table A](#).

Table A: *Digital Scanner Configurations*

Model Configuration	Description
DS2208-HC0000BZZRW	DS2208: Area Imager, Healthcare, Corded, HC White- LA, EMEA, APAC Only
DS2278-HC0000BZZRW	DS2278: Area Imager, Healthcare, Cordedless, HC White- LA, EMEA, APAC Only
CR2278-PC1000BRW	DS2278: Presentation Cradle, Bluetooth, Healthcare White - LA, EMEA, APAC Only

Related Product Line Configurations

The product configurations related to the DS2208-HC and DS2278-HC digital scanners are as follows.

- ✓ **NOTES** Check Solution Builder for additional information regarding all available accessories, and the latest available configurations.

Table B: *Accessories for the Digital Scanner*

Product ID	Description
22-71043-0BR	Gooseneck Intellistand. Weighted - DS2208, DS4308, DS8108, HC White
20-71043-0BR	Gooseneck Intellistand - DS2208, DS4308, DS8108, HC White

Cables

The full list of supported cables can be found at:

https://partnerportal.zebra.com/PartnerPortal/product_services/downloads_z/barcode_scanners/Universal-Cable-Guide-Bar-Code-Scanners.xlsx.

Chapter Descriptions

Topics covered in this guide are as follows:

- [Chapter 1, Getting Started](#) provides a product overview, unpacking instructions, and cable connection information.
- [Chapter 2, Maintenance & Technical Specifications](#) provides suggested digital scanner maintenance and technical specifications.
- [Chapter 3, User Preferences & Miscellaneous Options](#) describes each user preference feature and provides programming bar codes for selecting these features.
- [Chapter 4, Symbologies](#) describes all symbology features and provides programming bar codes for selecting these features for the digital scanner.

Notational Conventions

The following conventions are used in this document:

- Unless stated otherwise, **DS2200** refers to both corded and cordless versions of the digital scanner.
- *Italics* are used to highlight the following:
 - Chapters and sections in this and related documents
 - Dialog box, window and screen names
 - Drop-down list and list box names
 - Check box and radio button names

- **Bold** text is used to highlight the following:
 - Key names on a keypad
 - Button names on a screen.
- bullets (•) indicate:
 - Action items
 - Lists of alternatives
 - Lists of required steps that are not necessarily sequential
- Sequential lists (e.g., those that describe step-by-step procedures) appear as numbered lists.
- Throughout the programming bar code menus, asterisks (*) are used to denote default parameter settings.



* Indicates Default — * **Baud Rate 9600** — Feature/Option

Related Documents

- *DS2208 Series Quick Start Guide*, p/n MN-002873-xx - provides general information for getting started with the DS2208 digital scanner, and includes basic set up and operation instructions.
- *DS2278 Series Quick Start Guide*, p/n MN-002916-xx - provides general information for getting started with the DS2278 digital scanner, and includes basic set up and operation instructions.
- *Advanced Data Formatting Programmer Guide*, p/n 72E-69680-xx - provides information on ADF, a means of customizing data before transmission to a host.
- *Attribute Data Dictionary*, p/n 72E-149786-xx defines attribute numbers (device configuration parameters, monitored data, and born-on information) and describes management of various attribute domains for bar code scanners and OEM engines.

For the latest version of this guide and all guides, go to: www.zebra.com/support.

Service Information

If you have a problem using the equipment, contact your facility's technical or systems support. If there is a problem with the equipment, they will contact the Zebra Support & Downloads website at: www.zebra.com/support.

When contacting support, please have the following information available:

- Serial number of the unit
- Model number or product name
- Software type and version number

Zebra responds to calls by e-mail, telephone or fax within the time limits set forth in service agreements.

If your problem cannot be solved by support, you may need to return your equipment for servicing and will be given specific directions. Zebra is not responsible for any damages incurred during shipment if the approved shipping container is not used. Shipping the units improperly can possibly void the warranty.

If you purchased your business product from a Zebra business partner, please contact that business partner for support.

Provide Documentation Feedback

If you have comments, questions, or suggestions about this guide, send an email to EVM-Techdocs@zebra.com.

CHAPTER 1 GETTING STARTED

Introduction

Zebra's DS2200 Series for Healthcare is purpose-built to enhance patient care, clinician productivity and point-of-care operations. Unlike general purpose scanners, its disinfectant-ready housing withstands regular sanitizing. Additionally, Zebra's PRZM software decode algorithms capture challenging barcodes for first-time, every-time scanning to meet your healthcare needs at the patient bedside, pharmacy, and admitting.

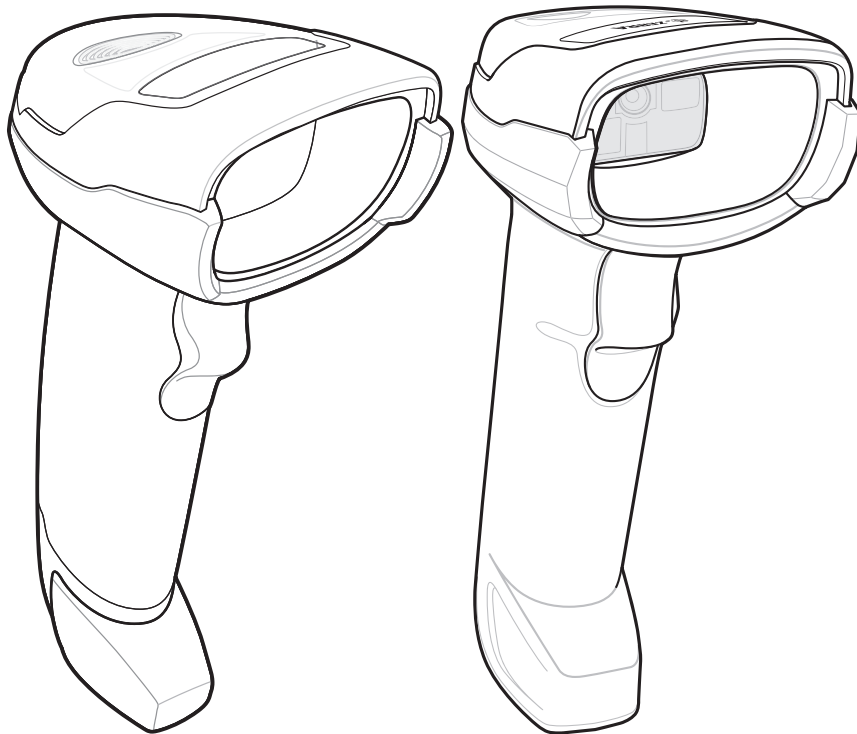

Figure 1-1 DS2208-HC (Left) & DS2278-HC (Right) Digital Scanners

Interfaces

The DS2208-HC and DS2278-HC digital scanners support:

- USB connection to a host. The digital scanner automatically detects the USB host interface type and uses the default setting (**USB Keyboard HID**). If the default (*) does not meet your requirements, select another USB interface type by scanning programming bar code menus.
- Standard RS-232 connection to a host. The digital scanner automatically detects the RS-232 host interface type and uses the default setting (**Standard RS-232**). If the default (*) does not meet your requirements, select another RS-232 interface type by scanning programming bar code menus.
- Connection to IBM 468X/469X hosts. The digital scanner automatically detects the IBM host interface type but does not select a default setting. Scan bar code menus to set up communication of the digital scanner with the IBM terminal.
- Keyboard Wedge connection to a host. The host interprets scanned data as keystrokes. The digital scanner automatically detects the Keyboard Wedge host interface type and uses the default setting (**IBM AT Notebook**).
- Configuration via 123Scan.

Unpacking

Remove the digital scanner from its packing and inspect it for damage. If the scanner was damaged in transit, contact support. See *page vii* for information. **KEEP THE PACKING**. It is the approved shipping container; use this to return the equipment for servicing.

Setting Up the DS2208-HC

Installing the Interface Cable

1. Insert the interface cable modular connector into the interface cable port on the rear of the digital scanner until you hear a click.

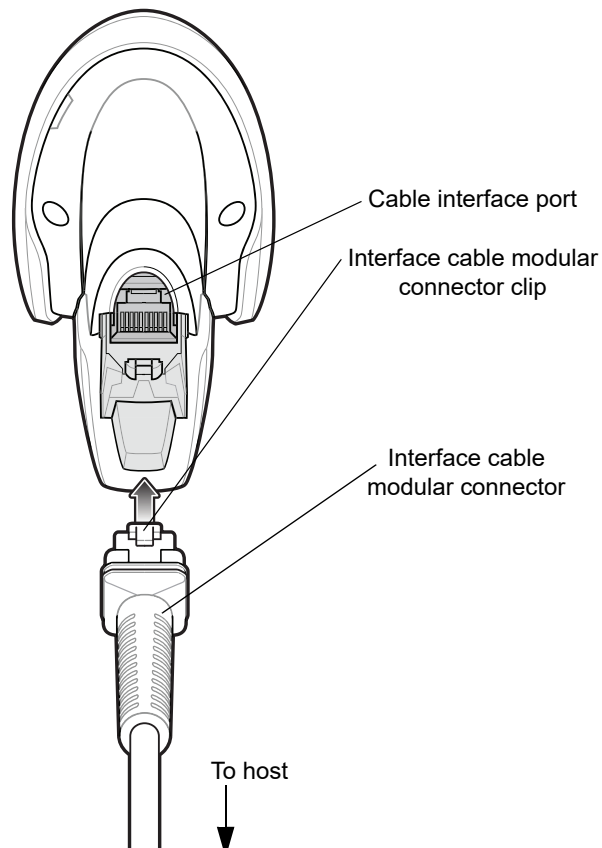

Figure 1-2 Installing the Cable - DS2208-HC



IMPORTANT Insert the cable into the cable interface port until a click sounds.

If you already have existing non shielded cables from legacy products (such as the LS2208) they can be reused. However, be aware that the shielded cables provide improved ESD performance. For regional information about cables and cable compatibility, go to the Zebra Partner Portal at: https://partnerportal.zebra.com/PartnerPortal/product_services/downloads_z/barcode_scanners/Universal-Cable-Guide-Bar-Code-Scanners.xlsx.

2. Gently tug the cable to ensure the connector is secure.
3. Connect the other end of the interface cable to the host (see the specific host chapter for information on host connections).

Removing the Interface Cable

1. Press the cable's modular connector clip through the access slot in the digital scanner's base.

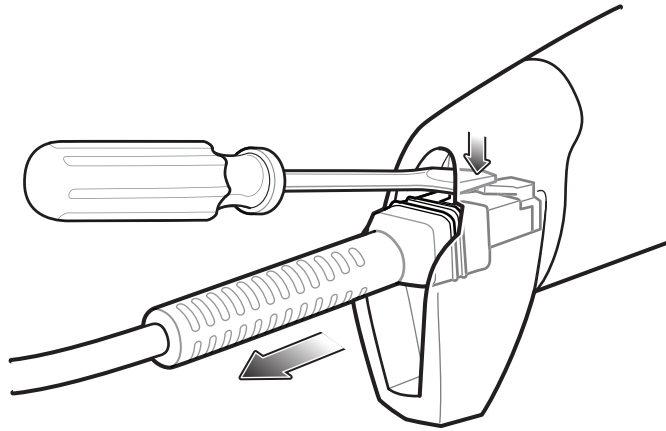

Figure 1-3 Removing the Cable

2. Carefully slide out the cable.
3. Follow the steps for [Installing the Interface Cable](#) to connect a new cable.

Connecting Power (if required)

If the host does not provide power to the digital scanner, connect an external power supply.

1. Plug the power supply into the power jack on the interface cable.
2. Plug the other end of the power supply into an AC outlet.

Configuring the Digital Scanner

To configure the digital scanner use the bar codes included in this manual, or use the 123Scan² configuration program. See [Chapter 3, User Preferences & Miscellaneous Options](#), and [Chapter 4, Symbologies](#) for information about programming the digital scanner using bar code menus.

Accessories

The digital scanner ships with the *DS2208 Quick Start Guide*. The following required accessories must be ordered:

- Interface cable for the appropriate interface. For example, a shielded connector cable when connecting via USB. For regional information about cables and cable compatibility, go to the Zebra Partner Portal at: https://partnerportal.zebra.com/PartnerPortal/product_services/downloads_z/barcode_scanners/Universal-Cable-Guide-Bar-Code-Scanners.xlsx.

✓ **IMPORTANT** If you already have existing non shielded cables from legacy products (such as the LS2208) they can be reused. However, be aware that the shielded cables provide improved ESD performance.

- Universal power supply, if the interface requires this.
- Gooseneck Intellistand for hands-free operation of the DS2208-HC.

For additional items, contact a local Zebra representative or business partner.

Setting up the DS2278-HC



IMPORTANT **DO NOT** use the CR2278-PC cradle with any scanners other than the DS2278-HC digital scanner. No other cradles are compatible with the DS2278-HC.

DO NOT use the DS2278-HC digital scanner with any cradles other than the CR2278-PC cradle. No other scanners are compatible with the CR2278-PC cradle.

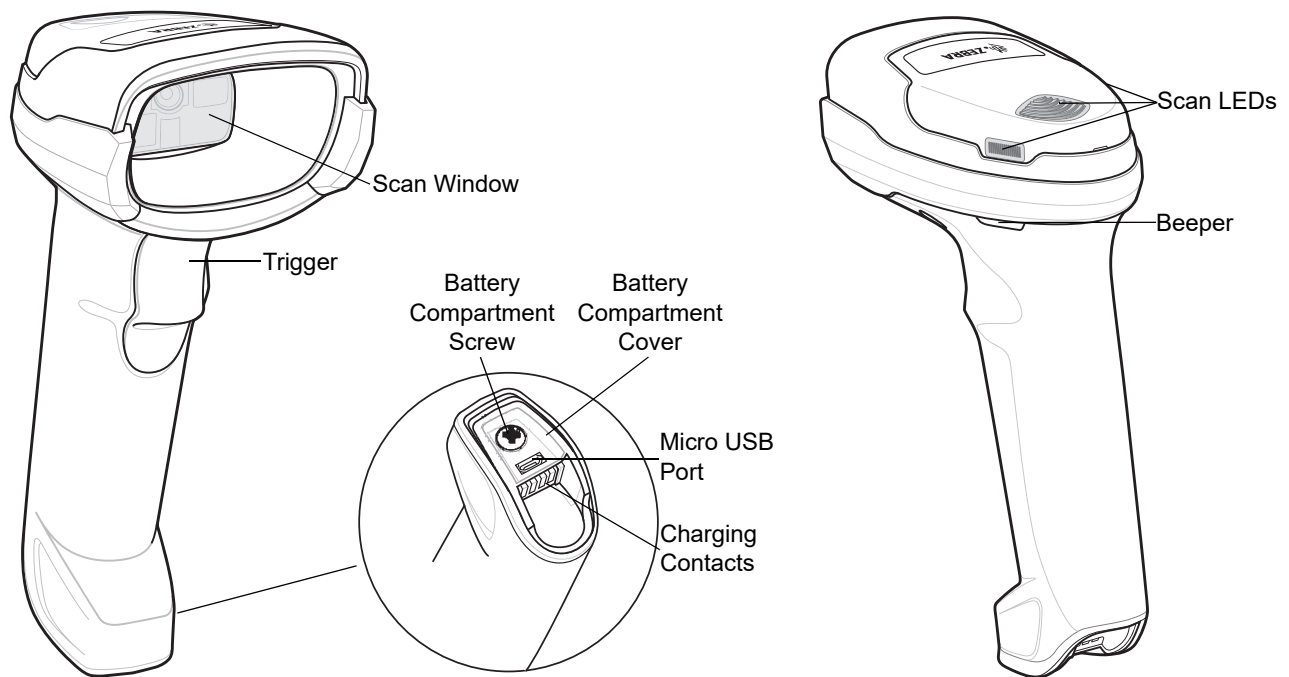

Figure 1-4 Digital Scanner Features

Cradle Features

- ✓ **NOTE** For detailed information about connecting, using, and mounting the CR2278-PC cradle refer to the documentation included with the cradle (*CR2278-PC Presentation Cradle Quick Reference Guide*, p/n MN-002917xx).

The CR2278-PC cordless presentation cradle serves as a charger, radio communication interface, and host communication interface for the DS2278-HC cordless digital scanner.

The presentation cradle sits on a desktop and charges the DS2278-HC cordless digital scanner while allowing bar code scanning in presentation mode. This cradle also provides host communication by receiving digital scanner data via a Bluetooth radio, and sending that data to the host through an attached cable. The cable provides power to the cradle from the host or optional power supply if supported.

Using a DC Power Supply

There is no separate power jack on the cradle. The cradle can operate from host supplied power, if available. If host power is limited or not available, an external DC power supply can be used with certain host interface cables that support a power jack. An external power supply is recommended if fastest charging is required. See host interface chapters for connections.



CAUTION Always disconnect the DC power supply BEFORE disconnecting the cable to the host end or the cradle may not recognize the new host.

Charging the DS2278-HC Battery

When using a new battery in the DS2278-HC, the battery may require a charge to be enabled.



- NOTES**
1. It is recommended to fully charge the battery before first use.
 2. Charge time depends on the host type and power source.
 3. The CR2278-PC passes 5V to the digital scanner which charges the battery. The charging system on the DS2278-HC charges the battery with as much current as possible based on the power source of the CR2278-PC. This way the input power source is never overloaded and the charge time is made as short as possible. Charge times lengthen as scanning activity increases when a DS2278-HC operates in presentation mode on a CR2278-PC cradle. To optimize charge performance, ensure the digital scanner is oriented to minimize accidental scan activation.



CAUTION The battery does not charge when the temperature is above 40°C (104°F). When scanning in presentation mode at temperatures above 40°C (104°F), the battery drains until the temperature drops. When the battery charge is consumed the digital scanner stops scanning until the temperature drops and the battery has sufficient time to charge.

To avoid temperature related faults, charge the battery and operate the DS2278 in presentation mode on a CR2278-PC only within the recommended 0°C to 40°C (32°F to 104°F) range, and ideally within 5°C to 35°C (41°F to 95°F).

Charging Using the Cradle

Insert the battery in the DS2278-HC and place the DS2278-HC in the CR2278-PC cradle (see *Inserting the DS2278-HC in the Cradle on page 1-11*). The digital scanner boots and the cradle LED begins flashing green to indicate the start of normal charging.

Presentation Cradle

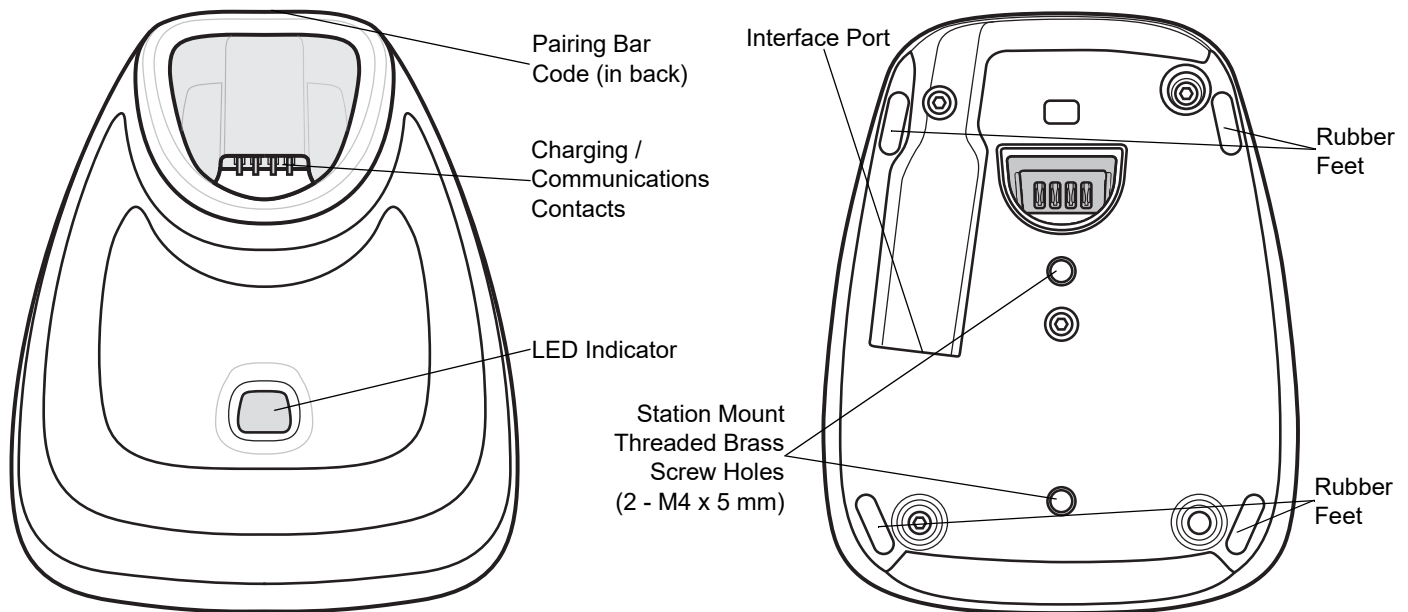

Figure 1-5 CR2278-PC (Presentation Cradle) -Top and Bottom Views

Connecting the Cradle

Via Host Connection (for Charging and Communication)

1. Connect the appropriate cable to the power supply and an AC power source, if necessary. This ensures detection of the host and prevents inadvertently back powering the cradle from improper detection of the host.
2. Insert the interface cable into the host port.
3. Insert the interface cable into the cradle's host port.
4. Pair the digital scanner to the cradle either by inserting it in the cradle (if Pair on Contacts is enabled) or by scanning the pairing bar code.
5. If necessary, scan the appropriate host bar code (for non-autodetected interfaces).

Via Wall Outlet Using a Power Adapter (for Charging Only)

1. Connect the appropriate cable to the power supply and an AC power source.
2. Insert the interface cable into the cradle's host port.
3. Pair the digital scanner directly to the host device (PC, Smartphone, or Tablet).

Changing the Host Interface

To connect to a different host, or to the same host through a different cable:

1. Unplug the interface cable from the host.
2. Unplug the power supply from the host cable, if required.
3. Connect the interface cable to the new host, or the new interface cable to the existing host.
4. Reconnect the power supply, if required.

If necessary, scan the appropriate host bar code (for non-autodetected interfaces).

Charging Using the Micro USB Cable

The Micro USB cable is a charge only cable.

✓ **NOTE** For best performance, we recommend using Zebra accessories.

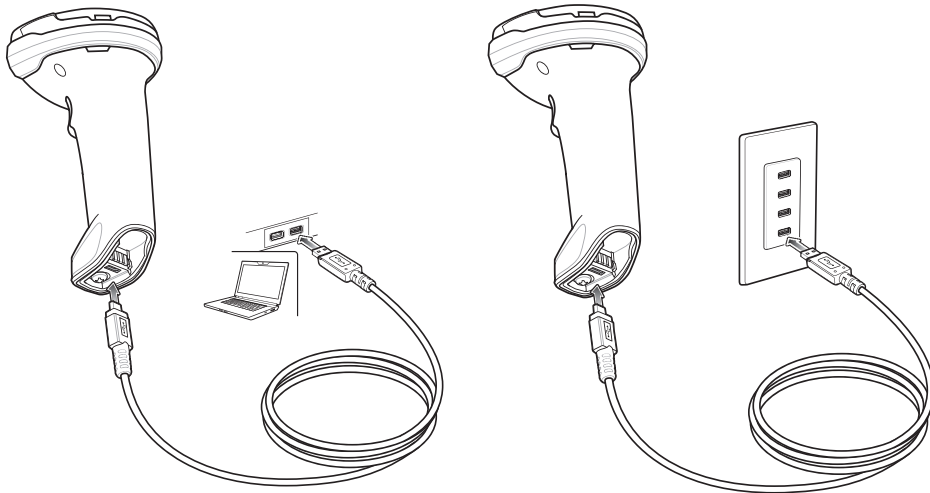

Figure 1-6 *Micro USB Connections*

Connect the Micro USB connector to the DS2278-HC. Connect the standard USB connector to a PC or a USB wall outlet. The digital scanner enumerates as a CDC device when the USB connector is plugged into a PC host. When charging begins, the digital scanner LED begins flashing green to indicate the start of normal charging.

Converting a CDC Device to HID

The digital scanner enumerates over USB as a CDC device, by default. If your host does not have a CDC driver, a delay occurs between connecting the digital scanner to the host and the start of charging. To eliminate the delay scan **HID Device Conversion** below to enumerate as an HID device. This allows the scanner to begin charging sooner.

To switch the digital scanner back to a CDC device, scan **Scanner as CDC Device** below.



HID Device Conversion



***Scanner as CDC Device**

Shutting Off the Digital Scanner Battery

Scan the **Battery Off** bar code below to shut off the battery for long term storage or shipping. Pull the digital scanner trigger to turn on the battery.



Battery Off

✓ **NOTE** Always scan the **Battery Off** bar code in hand-held mode.

Inserting the Battery

✓ **NOTES**

1. It is recommended to fully charge the battery before first use.
2. The battery is initially shipped inside the digital scanner. Inserting a battery would only be applicable for a replacement battery.

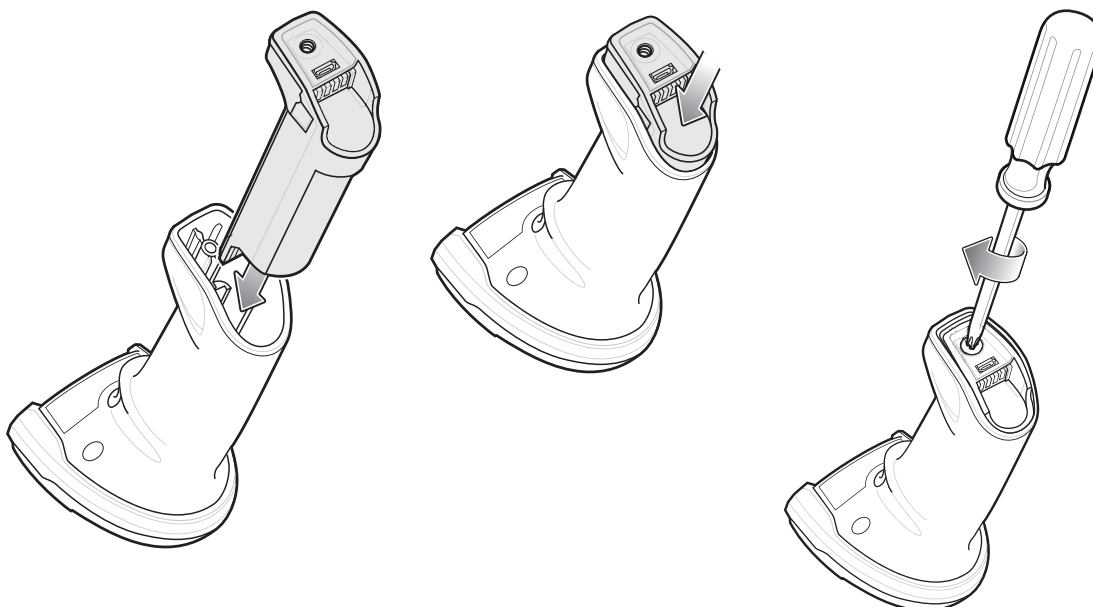

Figure 1-7 *Inserting the Battery*

To insert the battery into the digital scanner:

1. Insert the battery into the battery compartment and push down.

Turn the screw on the battery compartment clockwise to tighten. Do not over torque the screw.

Removing the Battery



IMPORTANT When replacing the battery, wait at least 5 seconds after removing the old battery before inserting the new battery.

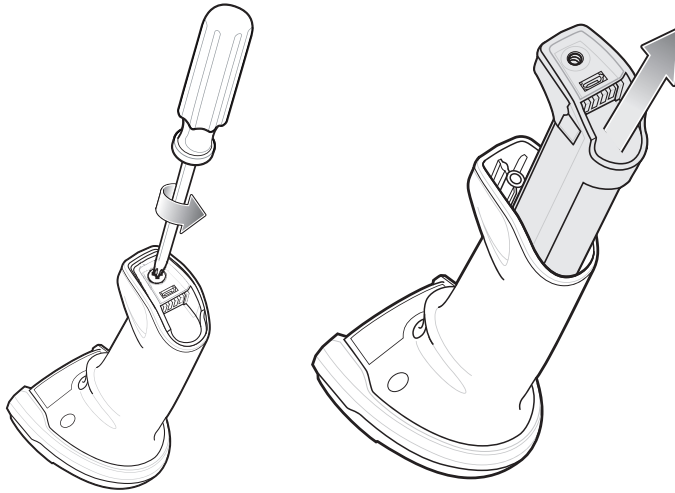

Figure 1-8 *Removing the Battery from the DS2778-HC*

To remove the battery from the digital scanner:

1. Turn the screw on the battery compartment counterclockwise to remove the screw.
2. Remove the battery from the battery compartment.
3. To replace the battery, see *Inserting the Battery* on page 1-9.

Inserting the DS2778-HC in the Cradle

To insert the digital scanner in the CR2278-PC cradle:

1. Insert the digital scanner straight down into the cradle top.
2. The digital scanner naturally rotates forward to engage the digital scanner contacts with the cradle contacts

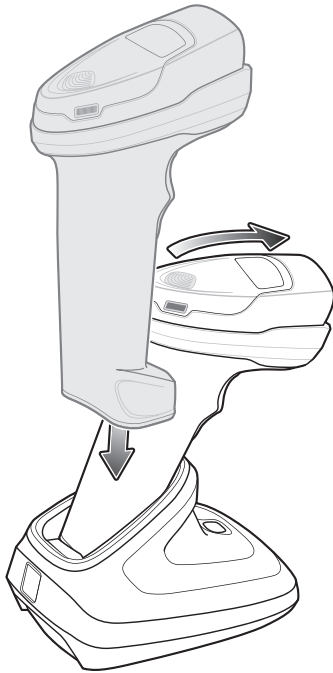

Figure 1-9 *Inserting the DS2778-HC Digital Scanner in the CR2278-PC Cradle*

Sending Data to the Host Computer

The cradle receives data from the digital scanner via a wireless radio connection and transmits it to the host computer via the host cable. The digital scanner and cradle must be paired for successful wireless communication.

Pairing

Pairing registers a digital scanner to the cradle such that the digital scanner and cradle can exchange information. Pair the digital scanner to the cradle either by inserting it in the cradle (if pair on contacts is enabled), or by scanning the pairing bar code.

To pair the digital scanner with the cradle, insert the digital scanner in the cradle or scan the pairing bar code.



NOTE The pairing bar code that connects the digital scanner to a cradle is unique to each cradle.

Do not scan data or parameters until pairing completes.

Lost Connection to Host

If scanned data does not transmit to the cradle's host, ensure that all cables are firmly inserted and the power supply is connected to an appropriate AC outlet, if applicable. If scanned data still does not transmit to the host, reestablish a connection with the host:

1. Disconnect the power supply from the cradle.
2. Disconnect the host interface cable from the cradle.
3. Wait three seconds.
4. Reconnect the host interface cable to the cradle.
5. Reconnect the power supply to the cradle, if the host requires.
6. Reestablish pairing with the cradle by inserting the digital scanner in the cradle or scan the pairing bar code.

Accessories

The digital scanner ships with the battery installed and the *DS2278 Quick Start Guide*. The following accessories must be ordered separately:

- Cradle: Can be used for charging the digital scanner battery and host communication.
- Micro USB cable: Can be used for charging the battery in the digital scanner, without a cradle.
- Replacement battery for the DS2278-HC digital scanner, if needed.
- Interface cable for the appropriate interface.
- Power supply, if the interface requires one.

See *Related Product Line Configurations on page xx* for the full list of accessories. Also see *Configurations on page xix* for product and cradle configurations. For additional items, contact a local Zebra representative or business partner.

CHAPTER 2 MAINTENANCE & TECHNICAL SPECIFICATIONS

Introduction

This chapter provides suggested digital scanner maintenance and technical specifications.

Maintenance



IMPORTANT Use pre-moistened wipes and do not allow liquid cleaner to pool.

Known Harmful Ingredients

The following chemicals are known to damage the plastics on Zebra scanners and should not come in contact with the device:

- Acetone
- Ammonia solutions
- Aqueous or alcoholic alkaline solutions
- Aromatic and chlorinated hydrocarbons
- Benzene
- Carboic acid
- Compounds of amines or ammonia
- Ethanolamine
- Ethers
- Isopropyl alcohol 70% (including wipes)
- Ketones
- TB-lysoform
- Toluene
- Trichloroethylene.

Approved Cleaners

- Hydrogen Peroxide
- Mild Dish Soap
- Clorox® Healthcare Bleach Germicidal Wipes
- Dispatch® with Bleach Wipes from Clorox®
- Sani-Cloth® Bleach Wipes

Cleaning the Digital Scanner

Routinely cleaning the exit window is required. A dirty window may affect scanning accuracy. Do not allow any abrasive material to touch the window.

To clean the scanner:

1. Dampen a soft cloth with one of the approved cleaning agents listed above or use pre-moistened wipes.
2. Gently wipe all surfaces, including the front, back, sides, top and bottom. Never apply liquid directly to the scanner. Be careful not to let liquid pool around the scanner window, trigger, cable connector or any other area on the device.
3. Be sure to clean the trigger and in between the trigger and the housing (use a cotton-tipped applicator to reach tight or inaccessible areas).
4. Do not spray water or other cleaning liquids directly into the exit window.
5. Wipe the scanner exit window with a lens tissue or other material suitable for cleaning optical material such as eyeglasses.
6. Immediately dry the scanner window after cleaning with a soft non-abrasive cloth to prevent streaking.
7. Allow the unit to air dry before use.
8. Scanner connectors:
 - a. Dip the cotton portion of a cotton-tipped applicator in isopropyl alcohol.
 - b. Rub the cotton portion of the cotton-tipped applicator back-and-forth across the connector on the Zebra scanner at least 3 times. Do not leave any cotton residue on the connector.
 - c. Use the cotton-tipped applicator dipped in alcohol to remove any grease and dirt near the connector area.
 - d. Use a dry cotton tipped applicator and rub the cotton portion of the cotton-tipped applicator back-and-forth across the connectors at least 3 times. Do not leave any cotton residue on the connectors.



NOTE If after performing these checks the digital scanner still experiences problems, contact the distributor or call support.

Technical Specifications

Table 2-1 *Technical Specifications*

Item	Description
Physical Characteristics	
Dimensions	<p>Corded DS2208-HC Imager: 6.5 in. H x 2.6 in. W x 3.9 in. D 16.5 cm. H x 6.6 cm. W x 9.8 cm. D</p> <p>Cordless DS2278-HC Imager: 6.9 in. H x 2.6 in. W x 3.5 in. D 17.5 cm. H x 6.6 cm. W x 9.0 cm. D</p> <p>Presentation Cradle: 2.8 in. H x 3.7 in. W x 4.8 in. D 7.2 cm. H x 9.4 cm. W x 12.2 cm.</p>
Weight	<p>Corded DS2208-HC Imager: 5.7 oz. / 161.6 g Cordless DS2278-HC Imager: 7.5 oz. / 214 g Presentation Cradle: 5.2 oz. / 151 g</p>
Input Voltage Range	DS2208-HC/DS2278-HC Imagers and Cradle: 4.5 to 5.5 VDC Host Powered; 4.5 to 5.5 VDC External Power Supply
Operating Current at Nominal Voltage (5.0V)	<p>Corded DS2208-HC Imager: 250 mA (typical). Note: Auto-Aim and Illumination on Acquiring Image</p>
Standby Current (idle) at Nominal Voltage (5.0V)	<p>Corded DS2208-HC Imager: 150 mA (typical). Note: Auto-Aim On Presentation Cradle and Micro USB Cable: 500 mA (typical) BC 1.2 USB</p>
Color	Healthcare White
Supported Host Interfaces	USB, RS232, Keyboard Wedge, TGCS (IBM) 46XX over RS-485
USB Certification	USB Certification
Keyboard Support	Supports over 90 international keyboards
User Indicators	Direct Decode Indicator, Good Decode LEDs; rear view LEDs; beeper (adjustable tone and volume)
Performance Characteristics	
Motion Tolerance (Hand-Held)	Up to 5 in./13 cm. per second for 13 mil UPC
Swipe Speed (Hands-Free)	Up to 30.0 in./76.2 cm. per second for 13 mil UPC
Light Source	Aiming Pattern: Linear 624nm Amber LED
Illumination	(2) 645nm Super-Red LEDs

Table 2-1 Technical Specifications (Continued)

Item	Description
Imager Field of View	32.8° H x 24.8° V Nominal
Image Sensor	640 x 480 pixels
Minimum Print Contrast	15% minimum reflective difference
Skew Tolerance	+/- 65°
Pitch Tolerance	+/- 65°
Roll Tolerance	0° - 360°
User Environment	
Operating Temperature	DS2208-HC & DS2278-HC Imagers: 32.0° to 122.0° F / 0.0° to 50.0° C Presentation Cradle: 32.0° to 104.0° F / 0.0° to 40.0° C
Storage Temperature	-40.0° to 158.0° F / -40.0° to 70.0° C
Humidity	5% to 95% RH, non-condensing
Drop Specification	Designed to withstand multiple drops at 5.0 ft. /1.5 m to concrete
Tumble Specification	Designed to withstand 250 tumbles in 1.5 ft./1.5 m tumbler Note: 1 tumble = 0.5 cycle.
Environmental Sealing	IP52
Electrostatic Discharge (ESD)	DS2208-HC/DS2278-HC Imagers and CR2278 Cradle: ESD per EN61000-4-2, +/-15 KV Air, +/-8 KV Direct, +/-8 KV Indirect
Ambient Light Immunity	0 to 10,000 Foot Candles / 0 to 107,600 Lux
Accessories	
Gooseneck Intellistand	Stand for Hands-Free use
Radio Specifications	
Bluetooth Radio	Standard Bluetooth Version 4.0 with BLE: Class 2 33 ft. (10.0m), Serial Port and HID Profiles; output power adjustable down from 2.0 dBm in 8 Steps
Battery	
Battery Capacity/Battery Type	2,400 mAh Li-Ion Battery
Scans per Battery Charge	110,000 scans at 60 Scans per Minute or 50,000 scans at 10 Scans per minute
Operating Time per Full Charge	84.0 hours
Battery Charge Time (From Empty)	
Standard USB	14 Hour Shift: 4 hours Full Charge: 17 hours

Table 2-1 *Technical Specifications (Continued)*

Item	Description
BC1.2 USB	14 Hour Shift: 1 hour Full Charge: 5 hours
External 5V Source	14 Hour Shift: 1 hour Full Charge: 5 hours
Micro USB	14 Hour Shift: 1.5 hours Full Charge: 7 hours
BC1.2 Micro USB	14 Hour Shift: 1 hour Full Charge: 4 hours
Regulatory	
Environmental	RoHS EN 50581
Electrical Safety	EN 60950-1 2ed + A11 + A1 + A12 + A2:2013, IEC 60950-1 2ed + A1 + A2, UL 60950-1, CAN/CSA-C22.2 No. 60950-1-07
LED Safety	IEC 62471
IT Emissions	EN 55032 (Class B)
IT Immunity	EN 55024
Harmonic Current Emissions	EN 61000-3-2
Voltage Fluctuation and Flicker	EN 61000-3-3
Radio Frequency Devices	47 CFR Part 15, Subpart B, Class B
Digital Apparatus	ICES-003 Issue 6, Class B
Symbol Decode Capability	
1D	Code 39, Code 128, Code 93, Codabar/NW7, Code 11, MSI Plessey, UPC/EAN, I 2 of 5, Korean 3 of 5, GS1 DataBar, Base 32 (Italian Pharma)
2D	PDF417, MicroPDF417, Composite Codes, TLC-39, Data Matrix, GS1 DataMatrix, Maxicode, QR Code, GS1 QR Code, MicroQR, Aztec, Han Xin (Chinese Sensible)
Postal Codes	US Postnet, US Planet, UK Postal, Japan Postal, Australia Post, Royal Mail 4 State Customer, KIX Code (Dutch), UPU 4 State Postal FICS (Post US4), USPS 4 State Postal (Post US3), Mailmark
Minimum Element Resolution	
Code 39	4.0 mil

Table 2-1 *Technical Specifications (Continued)*

Item	Description
Code 128	4.0 mil
Data Matrix	6.0 mil
QR Code	6.7 mil
Utilities and Management	
123Scan	Programs scanner parameters, upgrades firmware, provides scanned bar code data and prints reports (see Chapter 2, 123Scan and Software Tools).
Symbol Scanner SDK	Generates a fully-featured scanner application, including documentation, drivers, test utilities and sample source code (www.zebra.com/ScannerSDKforWindows)
Scanner Management Service (SMS)	Remotely manages your Zebra scanner and queries its asset information (www.zebra.com/sms).

CHAPTER 3 USER PREFERENCES & MISCELLANEOUS OPTIONS

Introduction

You can program the scanner to perform various functions, or activate different features. This chapter describes user preference features and provides programming bar codes for selecting these features.

The scanner ships with the settings shown in [Table 3-1 on page 3-2](#) . If the default values suit requirements, programming is not necessary.

Setting Parameters

To set feature values, scan a single bar code or a short bar code sequence. The settings are stored in non-volatile memory and are preserved even when the scanner powers down.

✓ **NOTE** Most computer monitors allow scanning bar codes directly on the screen. When scanning from the screen, be sure to set the document magnification to a level where you can see the bar code clearly, and bars and/or spaces do not merge.

If not using the default host, select the host type (see each host chapter for specific host information) after the power-up beeps sound. This is only necessary upon the first power-up when connected to a new host.

To return all features to default values, see *Default Parameters on page 3-3*. Throughout the programming bar code menus, asterisks indicate (*) default values.

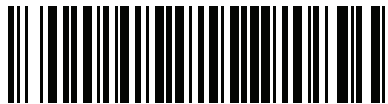

* Indicates default — *Enable Parameter — Feature/option
(1) — Option value

Scanning Sequence Examples

In most cases, scanning one bar code sets the parameter value. The scanner issues a fast warble beep and the LED turns green, signifying a successful parameter entry.

Errors While Scanning

Unless otherwise specified, to correct an error during a scanning sequence, just re-scan the correct parameter.

User Preferences/Miscellaneous Options Parameter Defaults

[Table 3-1](#) lists defaults for user preferences parameters. Change these values in one of two ways:

- Scan the appropriate bar codes in this chapter. The new value replaces the standard default value in memory. To recall default parameter values, see *Default Parameters on page 3-3*.

Table 3-1 *User Preferences Parameter Defaults*

Parameter	Parameter Number ¹	SSI Number ²	Default	Page Number
User Preferences				
Set Default Parameter			N/A	3-3
Do Not Disturb Mode (Direct Decode Indicator)	859	F2h 5Bh	Disable	3-4

1. Parameter number decimal values are used for programming via RSM commands.
2. SSI number hex values are used for programming via SSI commands.

User Preferences

Default Parameters

Scan one of the following bar codes to reset the scanner to its default settings as follows:

- **Restore Defaults** resets all default parameters as follows:
 - If you configured custom default parameter values via the **Write to Custom Defaults** bar code, scanning the **Restore Defaults** bar code restores these custom values.

Write to Custom Defaults

To create a set of custom defaults, select the desired parameter values in this guide, and then scan **Write to Custom Defaults**.



Restore Defaults



Set Factory Defaults



Write to Custom Defaults

Do Not Disturb Mode (Direct Decode Indicator)

Parameter # 859

SSI # F2h 5Bh

This parameter is only supported in Auto Aim and Standard (Level) Trigger Mode. Scan one of the following bar codes to select optional blinking of the illumination on a successful decode. You must continue to hold the trigger upon decode to see the illumination blink. If you release the trigger upon decode, the blinking does not occur. If you release the trigger upon decode, the blinking does not occur. This allows you to choose additional feedback for a successful decode by holding the trigger, or to continue to scan as normal.

- ***Disable Do Not Disturb Mode** - Illumination does not blink on a successful decode.
- **1 Blink** - Illumination blinks once upon a successful decode.
- **2 Blinks** - Illumination blinks twice upon a successful decode.



***Disable Do Not Disturb Mode
(0)**



**1 Blink
(1)**



**2 Blinks
(2)**

CHAPTER 4 SYMBOLOGIES

Introduction

You can program the scanner to perform various functions, or activate different features. This chapter describes symbology features and provides programming bar codes for selecting these features.

Setting Parameters

To set feature values, scan a single bar code or a short bar code sequence. The settings are stored in non-volatile memory and are preserved even when the scanner powers down.

✓ **NOTE** Most computer monitors allow scanning bar codes directly on the screen. When scanning from the screen, be sure to set the document magnification to a level where you can see the bar code clearly, and bars and/or spaces do not merge.

If not using a USB cable, select a host type (see each host chapter for specific host information) after the power-up beeps sound. This is only necessary upon the first power-up when connected to a new host.

To return all features to default values, see *Default Parameters on page 3-3*. Throughout the programming bar code menus, asterisks (*) indicate default values.

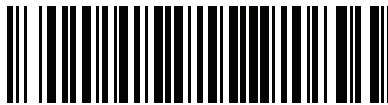

* Indicates default — ***Enable Parameter** — Feature/option

Scanning Sequence Examples

In most cases, scanning one bar code sets the parameter value. The scanner issues a fast warble beep and the LED turns green, signifying a successful parameter entry.

Errors While Scanning

Unless otherwise specified, to correct an error during a scanning sequence, just re-scan the correct parameter.

Symbology Parameter Defaults

[Table 4-1](#) lists defaults for all symbology parameters. Change these values in one of two ways:

- Scan the appropriate bar codes in this chapter. The new value replaces the standard default value in memory. To recall the default parameter values, see [Default Parameters on page 3-3](#).

Table 4-1 *Symbology Parameter Defaults*

Parameter	Parameter Number ¹	SSI Number ²	Default	Page Number
Enable/Disable All Code Types				4-3
Code 128				
ISBT Concatenation	577	F1h 41h	Enable	4-4
Code 128 Security Level	751	F1h EFh	Security Level 2	4-5
Composite Codes				
Composite CC-C	341	F0h 55h	Disable	4-7
Composite CC-A/B	342	F0h 56h	Disable	4-7

1. Parameter number decimal values are used for programming via RSM commands.
2. SSI number hex values are used for programming via SSI commands.

Enable/Disable All Code Types

Scan the **Disable All Code Types** bar code to disable all symbologies. This is useful when enabling only a few code types.

Scan **Enable All Code Types** to enable all symbologies. This is useful if you need to disable only a few code types.

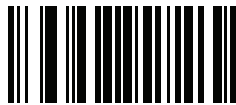

Disable All Code Types

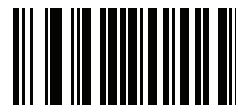

Enable All Code Types

ISBT Concatenation

Parameter # 577

SSI # F1h 41h

Select an option for concatenating pairs of ISBT code types:

- **Enable ISBT Concatenation** - There must be two ISBT codes in order for the scanner to decode and perform concatenation. The scanner does not decode single ISBT symbols.
- **Disable ISBT Concatenation** - The scanner does not concatenate pairs of ISBT codes it encounters.
- **Autodiscriminate ISBT Concatenation** - The scanner decodes and concatenates pairs of ISBT codes immediately.



***Enable ISBT Concatenation
(1)**



**Disable ISBT Concatenation
(0)**



**Autodiscriminate ISBT Concatenation
(2)**

Code 128 Security Level

Parameter # 751

SSI # F1h EFh

Code 128 bar codes are vulnerable to misdecodes, particularly when Code 128 Lengths is set to **Any Length**. The scanner offers four levels of decode security for Code 128 bar codes. There is an inverse relationship between security and scanner aggressiveness. Increasing the level of security can reduce scanning aggressiveness, so select only the level of security necessary.

- **Code 128 Security Level 0** - The scanner operates in its most aggressive state, while providing sufficient security in decoding most in-spec bar codes.
- **Code 128 Security Level 1** - This option eliminates most misdecodes while maintaining reasonable aggressiveness.
- **Code 128 Security Level 2** - This option applies greater bar code security requirements if **Security Level 1** fails to eliminate misdecodes.
- **Code 128 Security Level 3** - If you selected **Security Level 2**, and misdecodes still occur, select this security level to apply the highest safety requirements.

✓ **NOTE** Selecting this option is an extreme measure against mis-decoding severely out-of-spec bar codes, and significantly impairs the decoding ability of the scanner. If this level of security is required, try to improve the quality of the bar codes.

Code 128 Security Level (continued)

**Code 128 Security Level 0
(0)**



**Code 128 Security Level 1
(1)**



***Code 128 Security Level 2
(2)**



**Code 128 Security Level 3
(3)**

Composite

Composite CC-C

Parameter # 341

SSI # F0h 55h

Scan one of the following bar codes to enable or disable Composite bar codes of type CC-C.



Enable CC-C
(1)



*Disable CC-C
(0)

Composite CC-A/B

Parameter # 342

SSI # F0h 56h

Scan one of the following bar codes to enable or disable Composite bar codes of type CC-A/B.



Enable CC-A/B
(1)



*Disable CC-A/B
(0)

INDEX

A

accessories	1-4, 1-12
interface cable	1-4, 1-12
power supply	1-4, 1-12
shielded cables	1-3, 1-4

B

bar codes	
battery shut off	1-9
bookland ISBN	4-4
code 128 fnc4	4-5
code 128 security level	4-5, 4-6
composite CC-A/B	4-7
composite CC-C	4-7
disable all code types	4-3
enable all code types	4-3
HID device conversion	1-8
ISBT concatenation	4-4
set defaults	3-3
symbolologies	
default table	4-2
transmit no read message	3-4
user preferences	
default table	3-2
battery	
charging notes	1-6
charging with cradle	1-6
charging with micro USB	1-8
shut off	1-9
bluetooth	1-5
bullets	vii

C

cable configurations	.vi
cables	.vi

installing	1-3, 1-7
interface	1-4, 1-12
removing	1-4
shielded	1-3, 1-4
charging battery	
cradle	1-6
micro USB	1-8
notes	1-6
cleaning the device	
approved for standard devices	2-2
cleaning the devices	
how to	2-2
known harmful ingredients	2-1
code 128 bar codes	
fnc4	4-5
ISBT concatenation	4-4
security level	4-5, 4-6
composite bar codes	
composite CC-A/B	4-7
composite CC-C	4-7
configurations	v
cables	.vi
product line	.vi
connecting	
interface cable	1-3
lost connection	1-12
power	1-4
conventions	
notational	.vi
cradle	
connecting	1-7
inserting scanner	1-11
presentation	
features	1-7
supply power	1-6

D

default parameters 3-2
 setting 3-3
 symbolologies 4-2
 user preferences 3-2
 digital scanner
 features 1-5

F

features 1-5

M

maintenance 2-1
 approved cleaners 2-2
 how to clean the devices 2-2
 known harmful ingredients 2-1
 micro USB cable
 charging battery 1-8
 convert CDC device to HID 1-8
 HID device conversion 1-8

N

notational conventionsvi

P

pairing 1-11
 parts
 scanner 1-7
 power 1-6
 power supply 1-4, 1-12
 connecting 1-4
 product line configurationsvi

Q

quick start guide 1-4, 1-12

R

radio communication
 bluetooth 1-5

S

scanner parts 1-7
 scanning
 errors 3-2, 4-2
 sequence example 3-2, 4-2
 setting parameters 3-1, 4-1
 service information vii
 setting defaults 3-3
 setup

 connecting power 1-4
 inserting scanner in cradle 1-11
 installing interface cable 1-3
 lost host connection 1-12
 supplying power 1-6
 unpacking 1-2
 shut off battery 1-9
 specifications 2-3
 support vii
 symbology default parameters 4-2

T

technical specifications 2-3

U

unpacking 1-2
 UPC/EAN/JAN bar codes
 bookland ISBN 4-4



Zebra Technologies Corporation, Inc.
3 Overlook Point
Lincolnshire, IL 60069, U.S.A.
<http://www.zebra.com>

© 2019 ZIH Corp and/or its affiliates. All rights reserved. ZEBRA and the stylized Zebra head are trademarks of ZIH Corp, registered in many jurisdictions worldwide. All other trademarks are the property of their respective owners.